

# FL1000-SW

## FLOOR LEVEL PALLETIZER

The FL1000-SW combines a rugged, heavy-duty small footprint palletizer with the added functionality of a fully integrated, industry proven stretch wrapper. The FL1000-SW can simultaneously stack and stretch wrap a wide variety of package types, including cases, trays, totes, film only and display packs from a variety of industries. The FL1000-SW palletizes 10 cases per minute or more, depending on case size and pallet pattern.



### FEATURES

- Comprehensive Guard Package
- Category 3 Safety Electrical System
- Interlocked Access Doors to Load Build Area
- Full Height Light Curtains at Discharge
- Automatic Hoist Protection Pins
- Product Manager for Pattern Creation and Tuning
- Heavy Duty Sensor Mounts
- 4-Sided Pallet Stack Retention
- Stack Light / Beacon
- Smart Squeeze Technology for Misformed Layer Detection
- Low Pallet Detection
- Low Sheet Detection
- Heavy Duty Construction
- 80 Pitch Hoist Chain
- Infeed Tunnel Guard
- UL Approved or CSA Certified Control Panel
- Ethernet Enabled PLC with Distributed I/O
- Online parts ordering at [www.palletizing.com](http://www.palletizing.com)
- 24-Hour parts and service hotline [1.800.628.4065](tel:1.800.628.4065)

To view a video of the FL1000-SW in operation and for more information on Columbia's complete line of palletizers, please visit [www.palletizing.com](http://www.palletizing.com) or call toll-free at [1.800.628.4065](tel:1.800.628.4065) / direct at [1.360.694.1501](tel:1.360.694.1501).

## COMMON PALLETIZER LAYOUTS

- ① **Infeed**
- ② **Palletizer**
- ③ **Pallet Dispenser**
- ④ **Discharge**
- ⑤ **Stretch Wrapper**

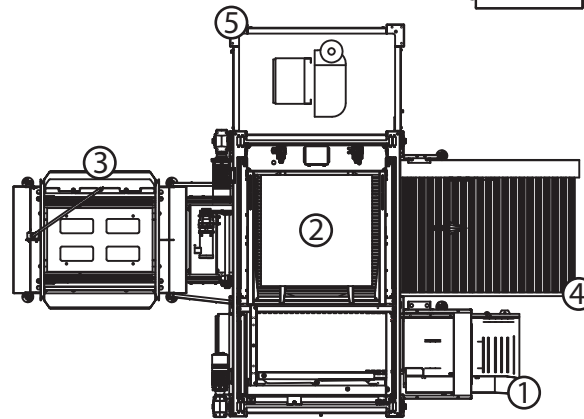
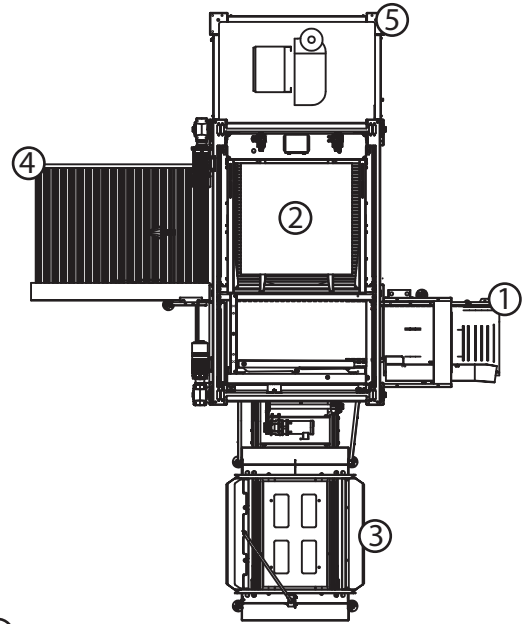
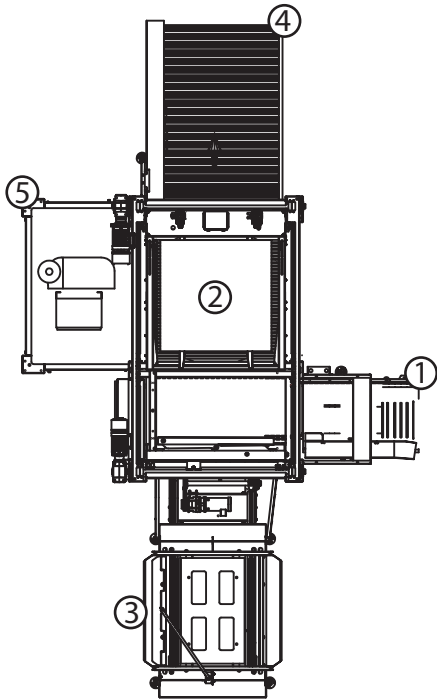

### OPTIONS

- Wireless controls interface
- Labels-out stacking
- Speed enhancement upgrades
- FDA accepted stainless steel paint
- Upstream and downstream conveyor and interfacing
- Discharge conveyor
- Slip / Tie / Cap sheet dispenser
- Unitizing
- Turnkey system integration
- Soft product handling